

# Southwest Washington Chapter of ICC

This construction detail is illustrative of the minimum standard of construction based upon the 2003 IRC / WAC 51-51

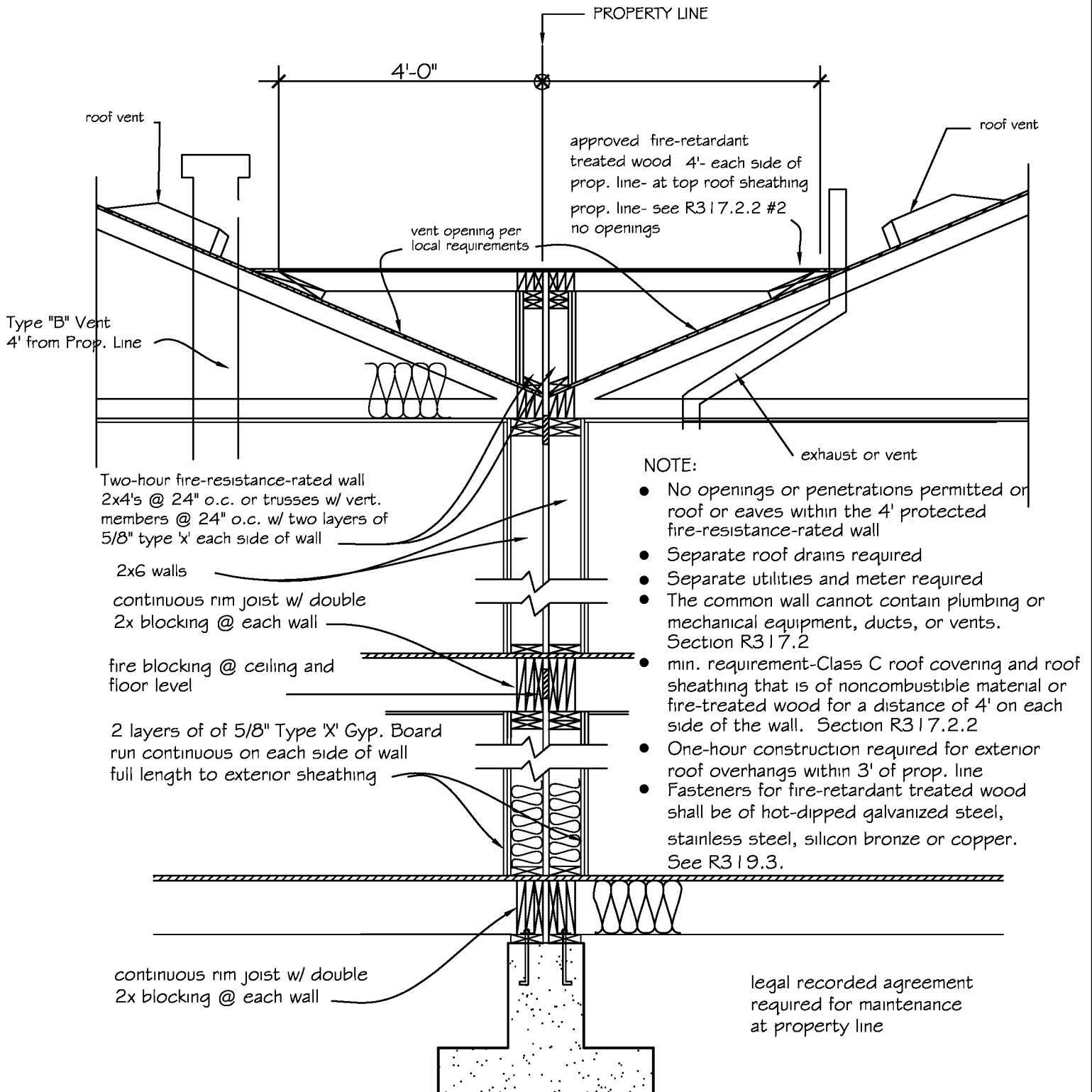

CONDITION SHOWN WITH RAFTERS OR TRUSSES PERPENDICULAR TO FIRE-RESISTANCE-RATED WALL  
SECTION R317.2.2 (Exception)-NO PARAPET REQUIRED WHEN BUILDING IS PROTECTED  
4 FEET EACH SIDE OF FIRE WALL W/FIRE RETARDANT-TREATED WOOD