

3.

MI 804.2.6-3

The vent termination point shall not be located closer than 3' to an interior corner formed by two walls perpendicular to each other.

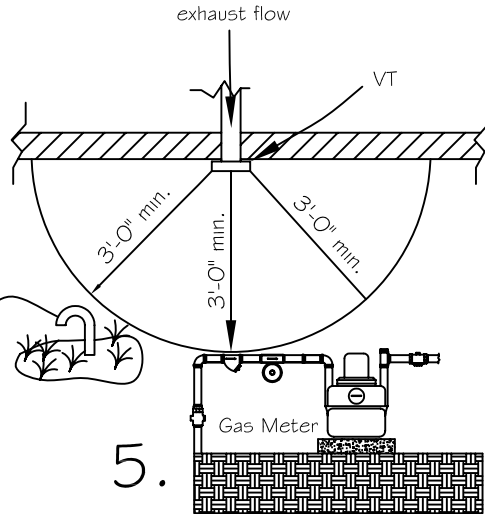

5.

The vent termination shall not be mounted directly above or within 3' horizontally of an oil tank vent or gas meter.

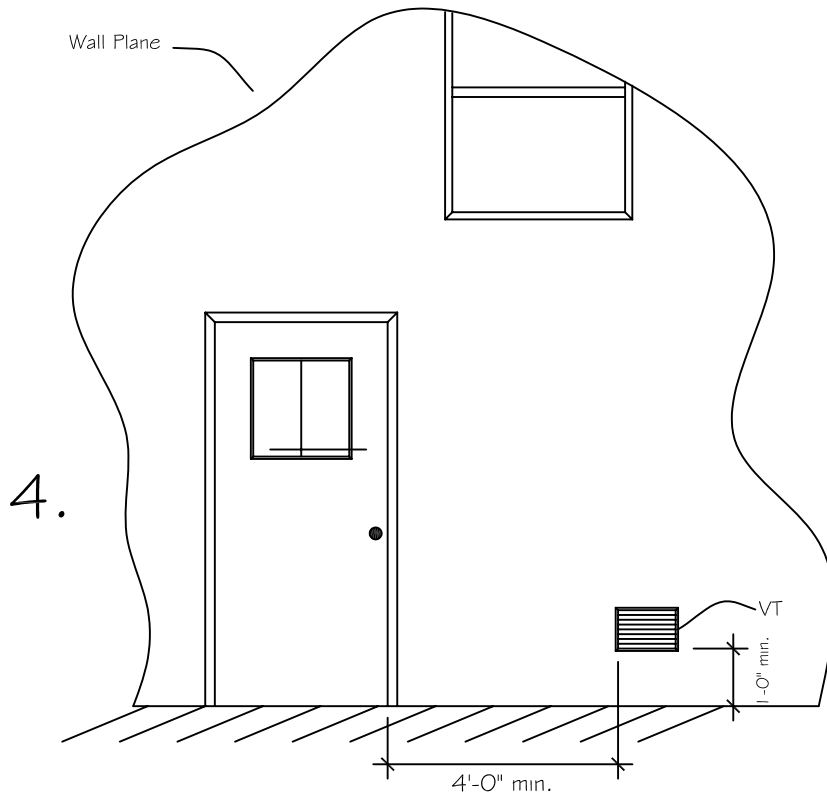

4.

The bottom of the vent termination shall be located at least 12" above finish grade level

6. Power exhauster termination shall be not less than 10' from the lot line and adjacent buildings.
7. The discharge shall be directed away from the building.

VT:vent termination
FAI:forced air inlet
GAI:Gravity Air Inlet