

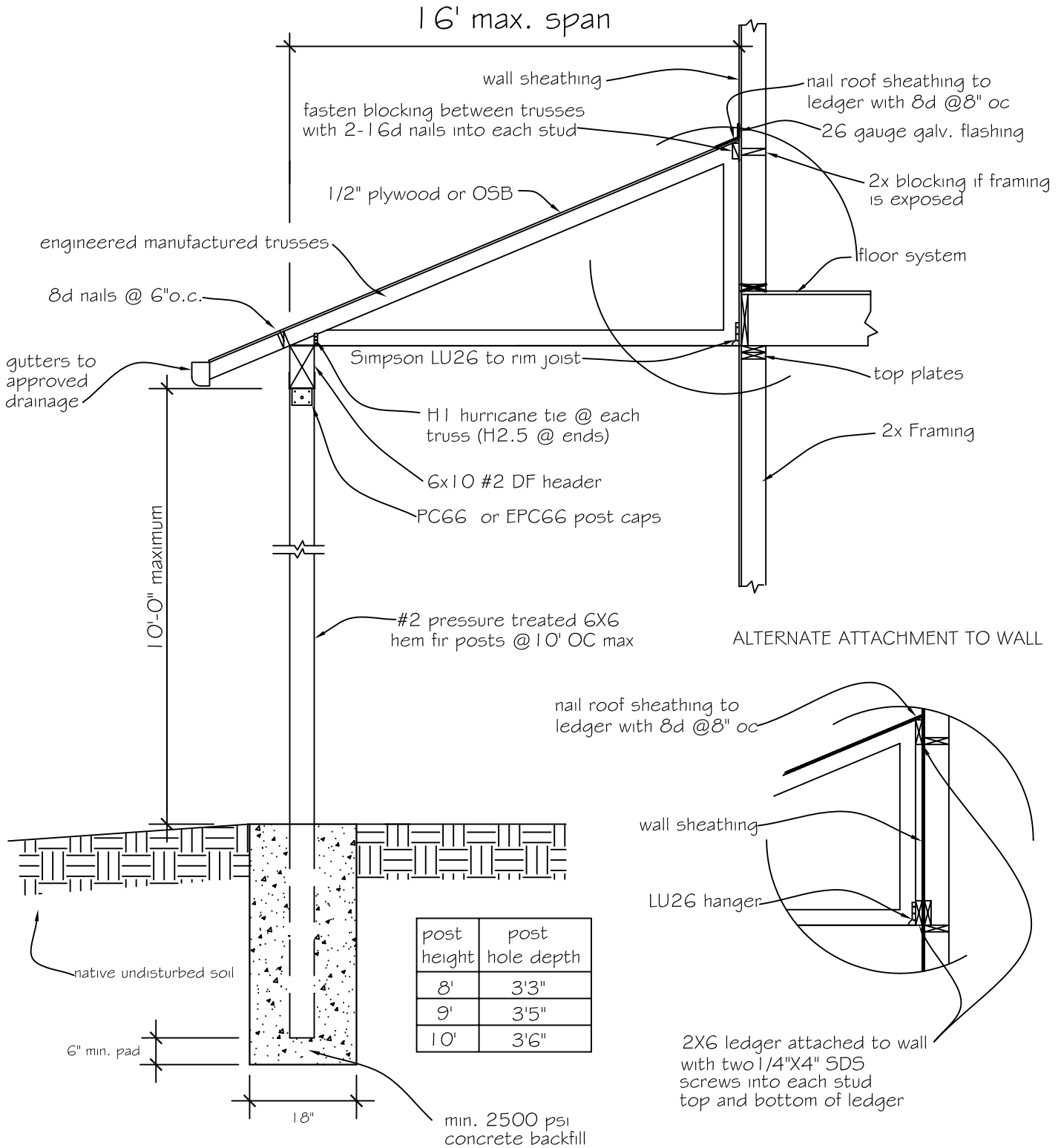

# Southwest Washington Chapter of ICC

This construction detail is illustrative of the minimum standard of construction based upon the 2006 IRC / WAC 51-51

Visit our web site at: [www.sww-icc.org](http://www.sww-icc.org)



Post Design  
IBC 1805.7