

Note: referenced standards are per ANSI A117.1-2003 unless otherwise noted

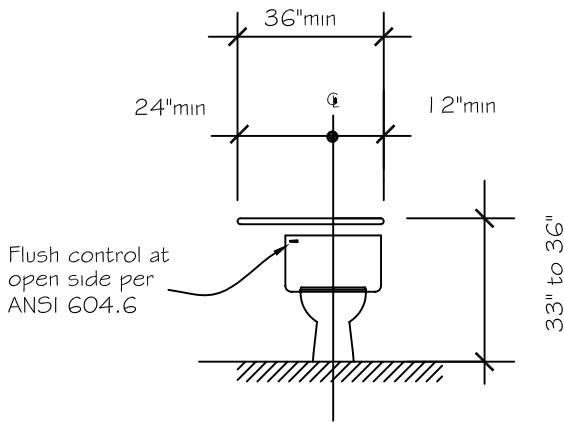

(a)

Back Wall  
Figure 604.5.2

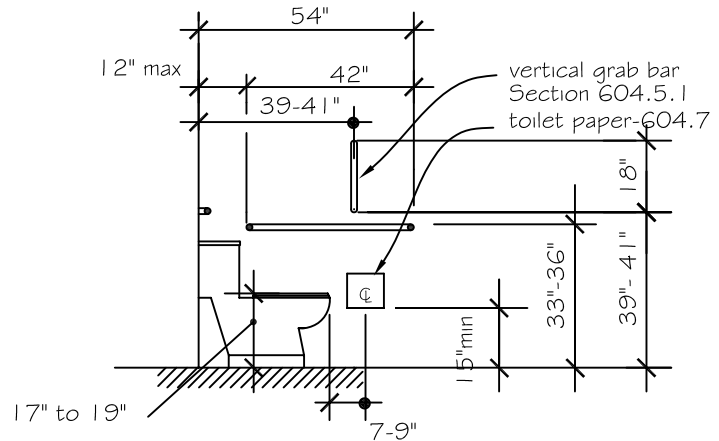

(b)

Side Wall  
Figure 604.5.1

## Figure 2 Grab Bars at Water Closets

### ANSI 604.5

(a) Back wall elevation. A 36" minimum length grab bar is required behind the water closet mounted at a height between 33" and 36"-Fig. 604.5.2. The grab bar must extend a minimum of 12" beyond the center of the water closet toward the side wall and a minimum of 24" toward the open side for either a left or right side approach. See Section 604.5.2.

(b) Side Wall. A 42" minimum length grab bar is required to the side of the water closet spaced 12" maximum from the back wall and extending a minimum of 54" from the back wall at a height between 33" to 36"- Figure 604.5.1. The toilet paper dispenser outlet mounted at 15" minimum and 48" maximum above the floor. See Section 604.7.

(c) Flush controls shall be hand operated or automatic. Hand operated flush controls shall comply with Section 309. Flush controls shall be located on the open side of the water closet.