

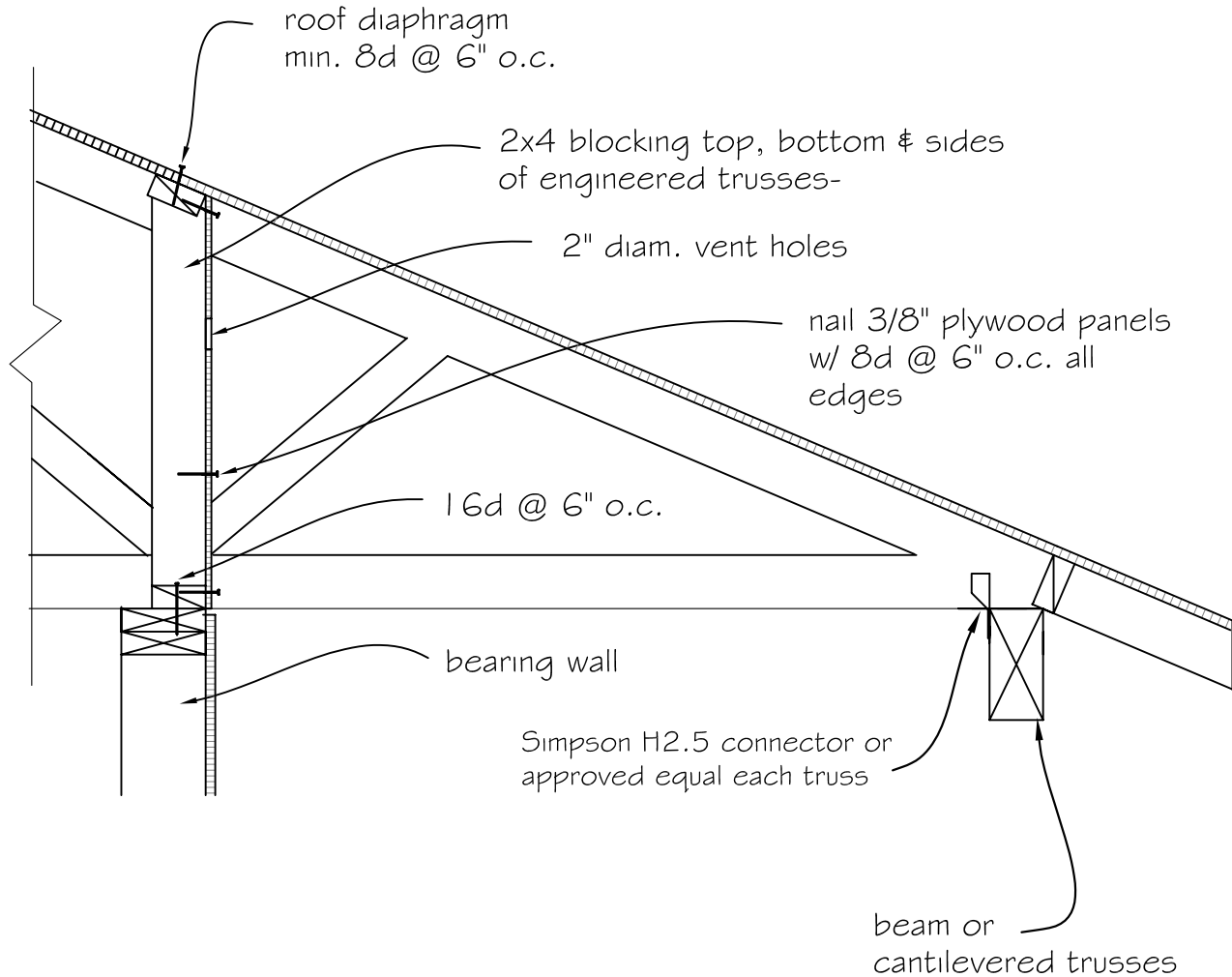

Southwest Washington Chapter of ICC

This construction detail is illustrative of the minimum standard of construction based upon the 2009 IRC / WAC 51-51

Visit our web site at: www.sww-icc.org



Blocking Detail at Truss Bearing