

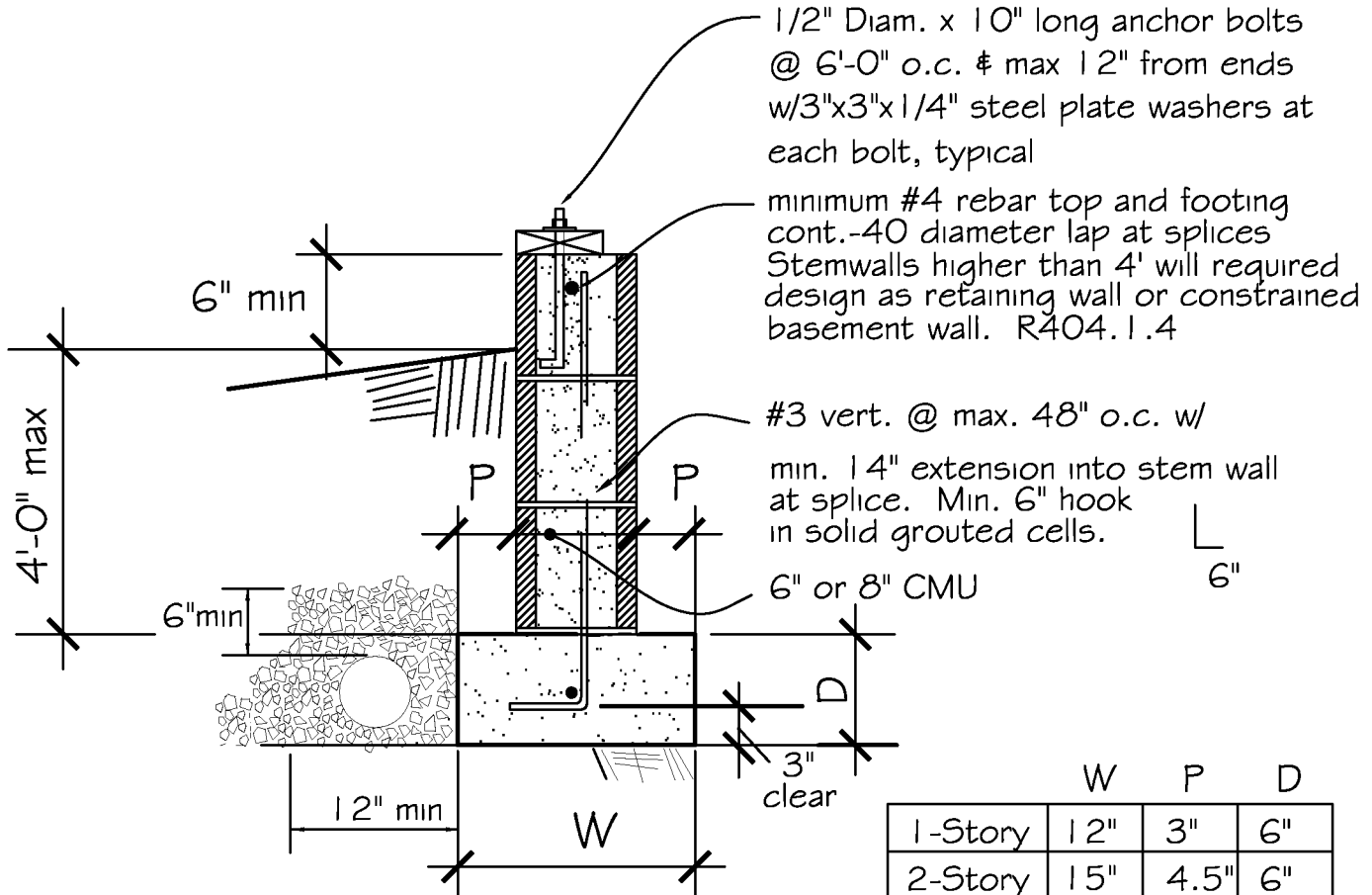

Southwest Washington Chapter of ICC

This construction detail is accepted as meeting the minimum standard of construction as based upon the 2003 IRC / WAC 51-51 requirements and is accepted in the following regional jurisdictions

Cities of; Camas, Centralia, Kalama, Ridgefield, Castle Rock, Vancouver, Washougal, Winlock, Wooland, Longview, Battle Ground, Counties of; Clark, Cowlitz, Skamania, Lewis



* see footnote 3

Note:

- Grade shall fall a minimum of 6" in the first 10' or footing drain will be required. See IRC 401.3.
- Drainage to be 3" diam. perforated pipe with 3/4" min. crushed rock or gravel and approved filter membrane. See R405.1.
- Anchor bolt space for 3-story building shall be 48" o.c.
- Footing projection P min. 2" and shall not exceed footing depth.
- Vertical and horizontal wall reinforcements shall be placed no closer to the outside face of the wall than one-half the wall thickness.
- Maximum 4'-0" high stemwall with no surcharge permitted (IRC 404.1.3). See basement wall detail for higher stemwalls.