

Southwest Washington Chapter of ICC

This construction detail is illustrative of the minimum standard of construction based upon the 2003 IRC / WAC 51-51

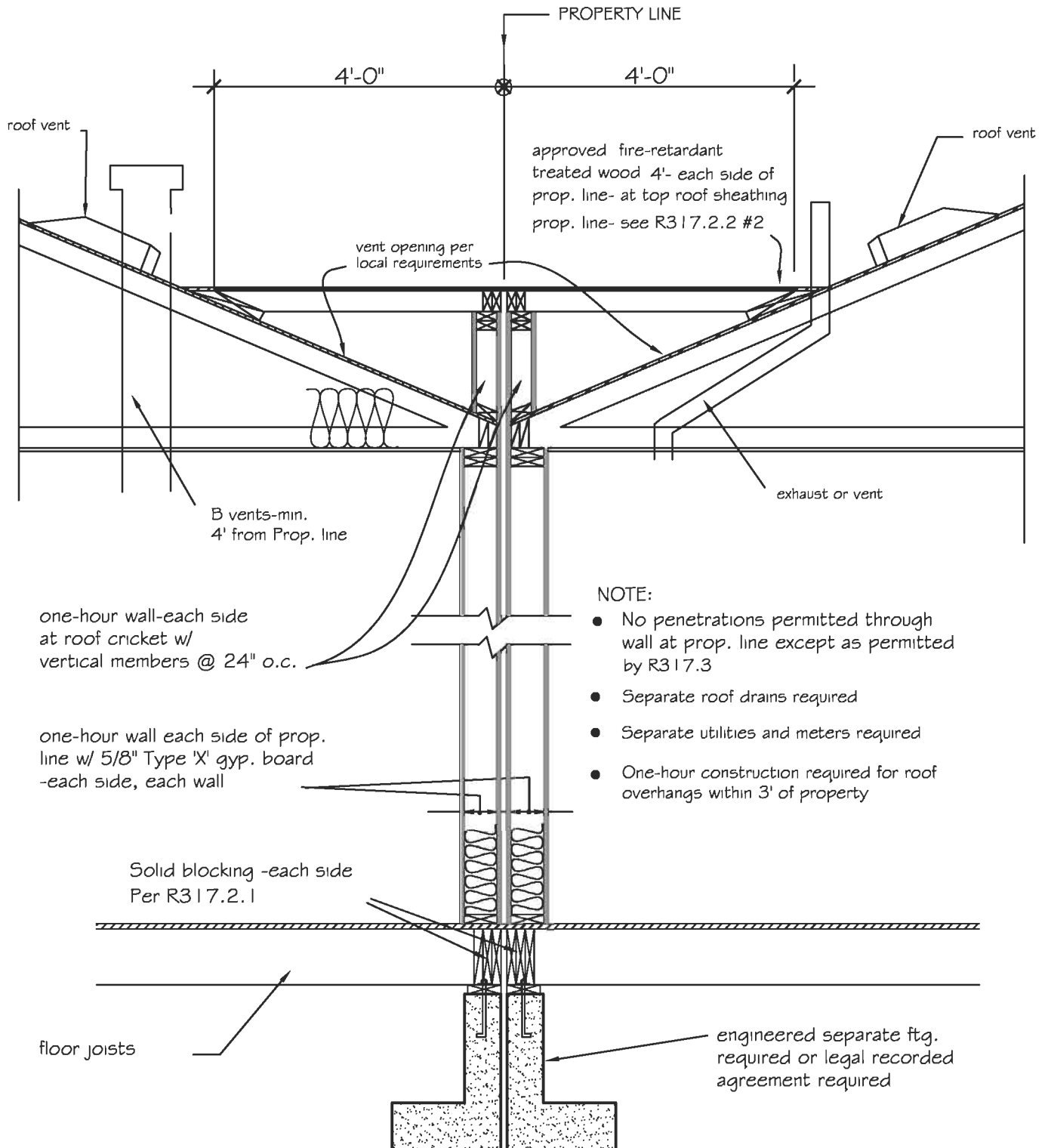

CONDITION SHOWN WITH RAFTERS OR TRUSSES PERPENDICULAR TO PROPERTY LINE,