

Southwest Washington Chapter of ICC

This construction detail is illustrative of the minimum standard of construction based upon the 2003 IBC / WAC 51-50

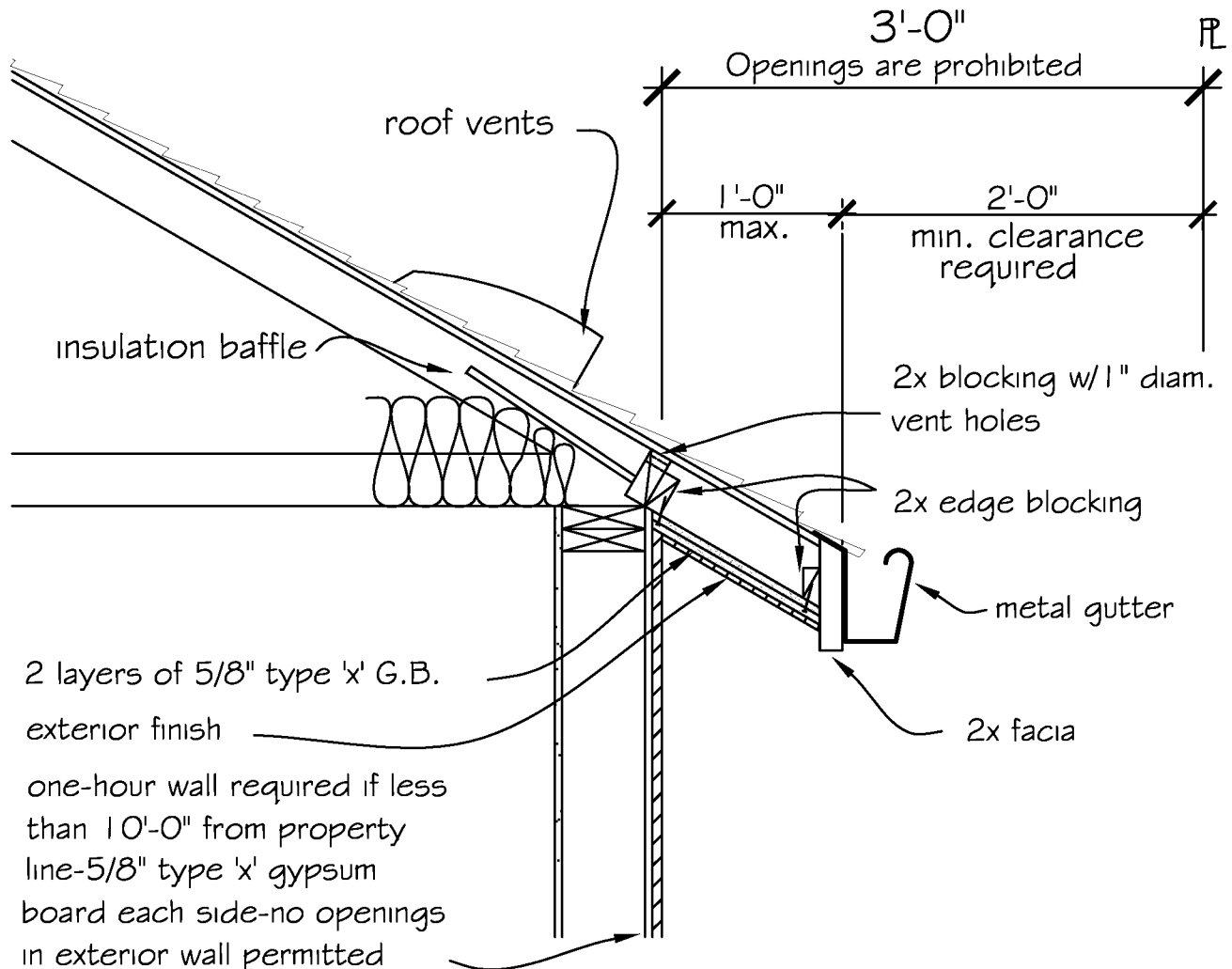

- * No openings permitted less than 3' from property line-See Table 704.8
- * Protection of openings and one-hour construction starts where exterior walls are less than 10' from property line-see IBC Tables 704.8 & 602
- * Parapet requirements less than 10' from property line-See 704.11
- * No unprotected openings less than 5' from property line- IBC Table 704.8

EAVE OVERHANG PROTECTION FOR B/M/S OCCUPANCIES 5B CONSTRUCTION