

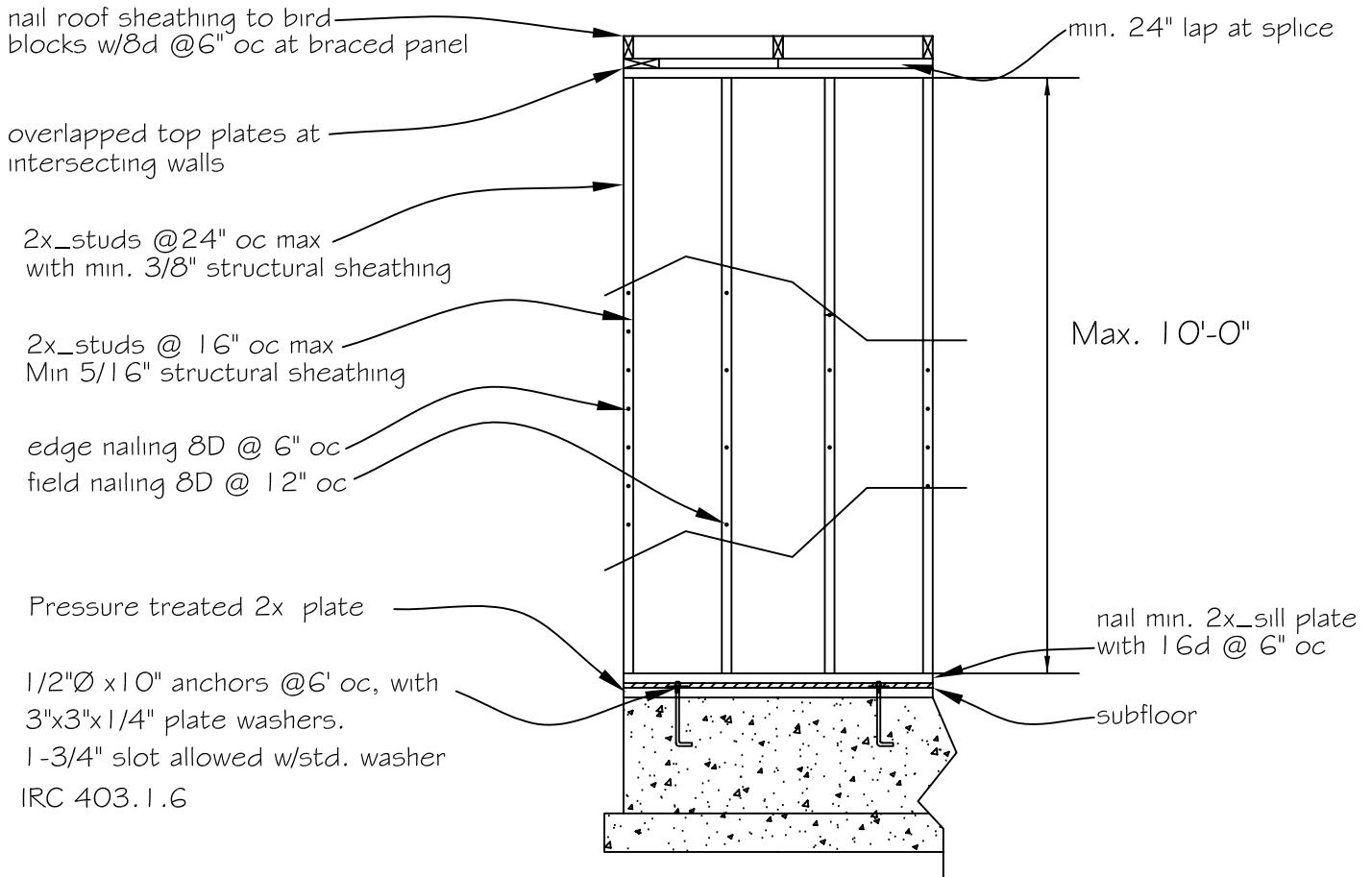

Southwest Washington Chapter of ICC

This construction detail is illustrative of the minimum standard of construction based upon the 2006 IRC / WAC 51-51

Visit our web site at: www.sww-icc.org



NOTES

- 1.) All vertical panel joints shall occur over, and be fastened to common studs. R602.10.7 (WAC 51-51)
- 2.) All horizontal joints shall occur over, and be fastened to, common blocking. of a minimum 2" nominal thickness
- 3.) See R602.10.11.1 for braced wall line spacing
- 4.) Panel method R602.10.3.3-method 3 depicted
- 5.) For masonry veneer see R703.7 for additional bracing requirements