

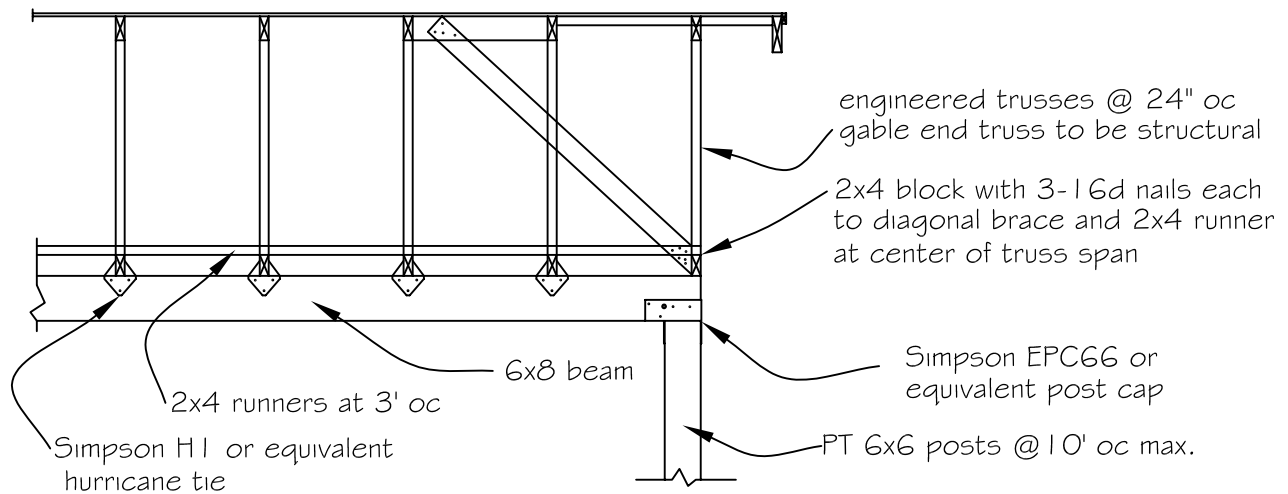

Southwest Washington Chapter of ICC

This construction detail is illustrative of the minimum standard of construction based upon the 2006 IRC / WAC 51-51

Visit our web site at: www.sww-icc.org

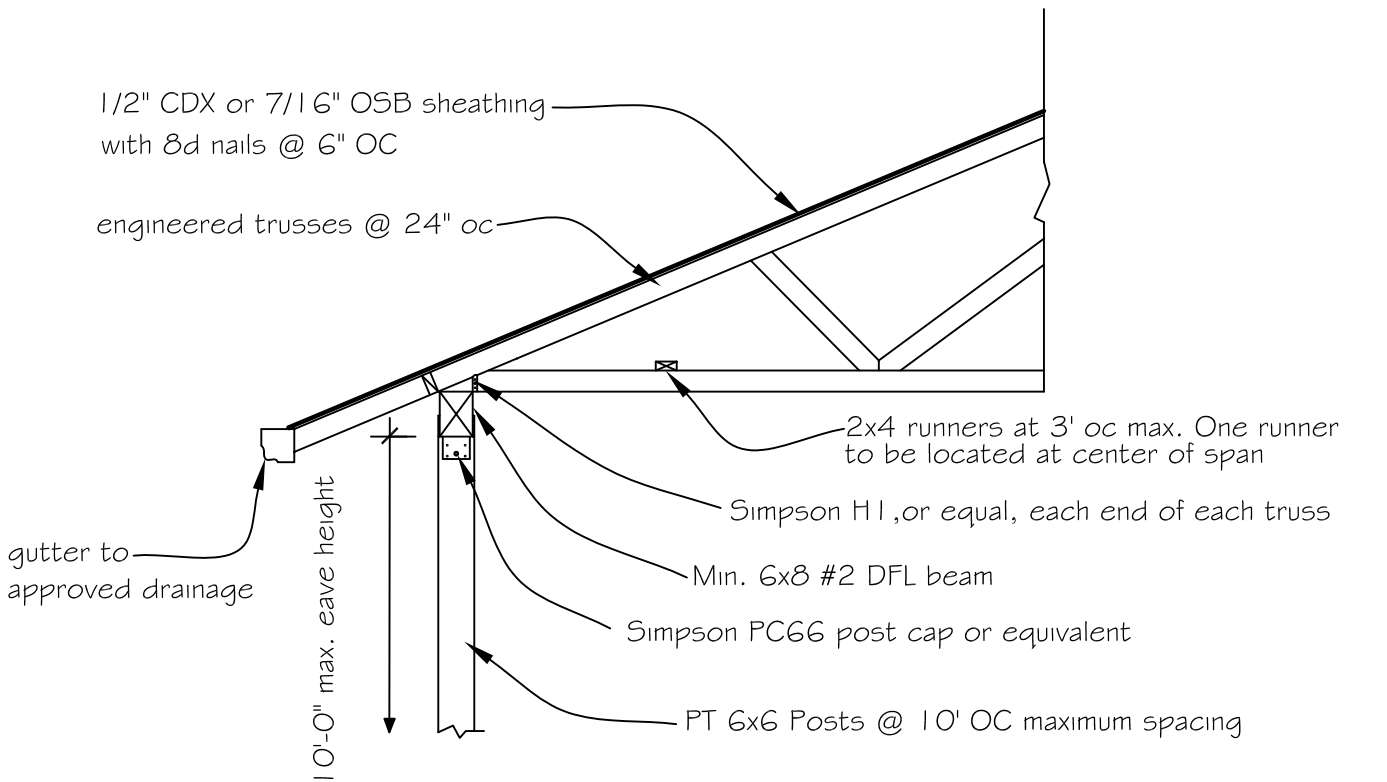

Post and beam with 24" oc truss details

See detail Page 2 for foundation requirements

Post Design
IBC 1805.7