

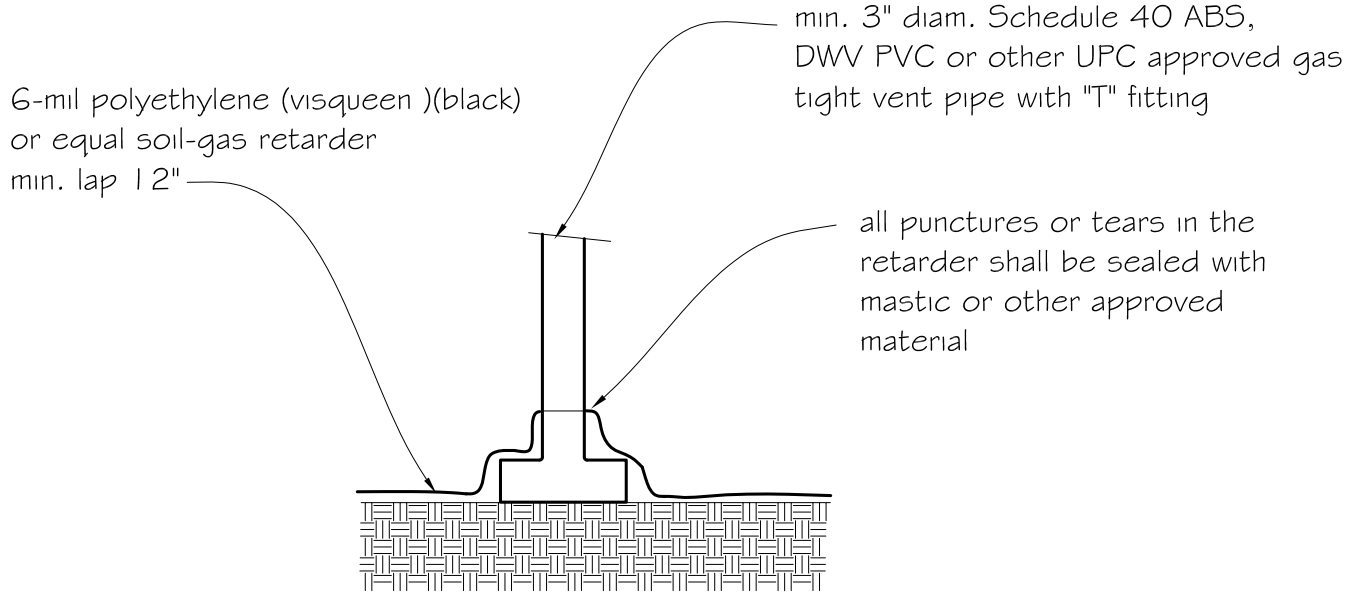

Southwest Washington Chapter of ICC

This construction detail is illustrative of the minimum standard of construction based upon the 2009 IRC / WAC 51-51



Radon Vent Pipe @ Crawl Space

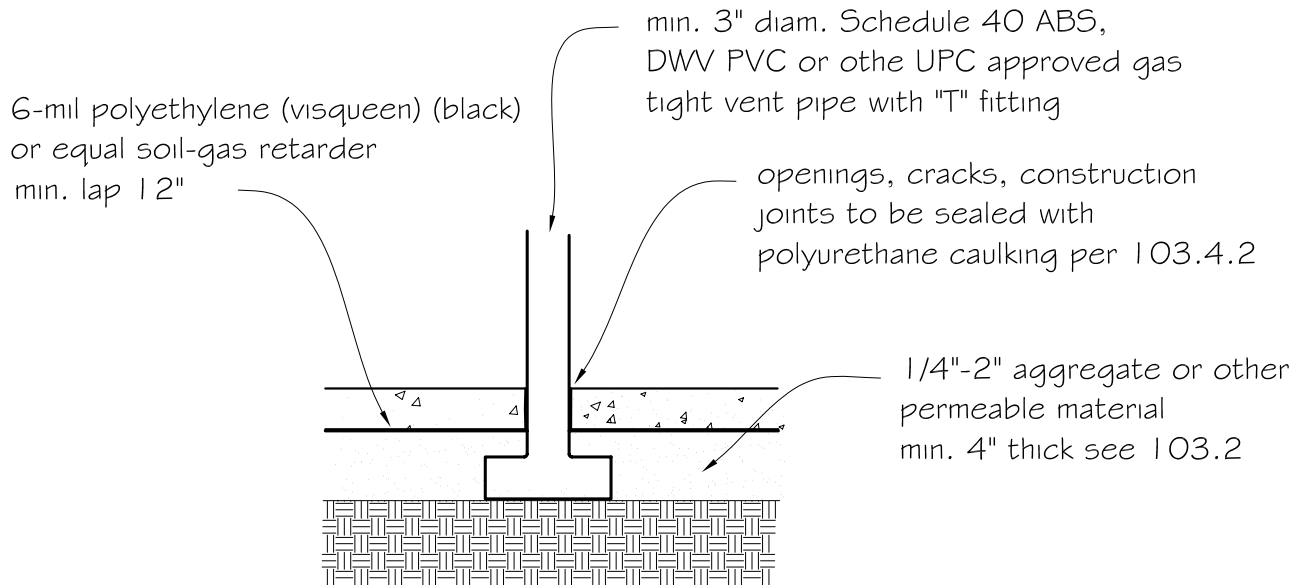

Radon Vent Pipe @ Slab