

Southwest Washington Chapter of ICC

This construction detail is illustrative of the minimum standard
of construction based upon the 2006 IRC / WAC 51-51

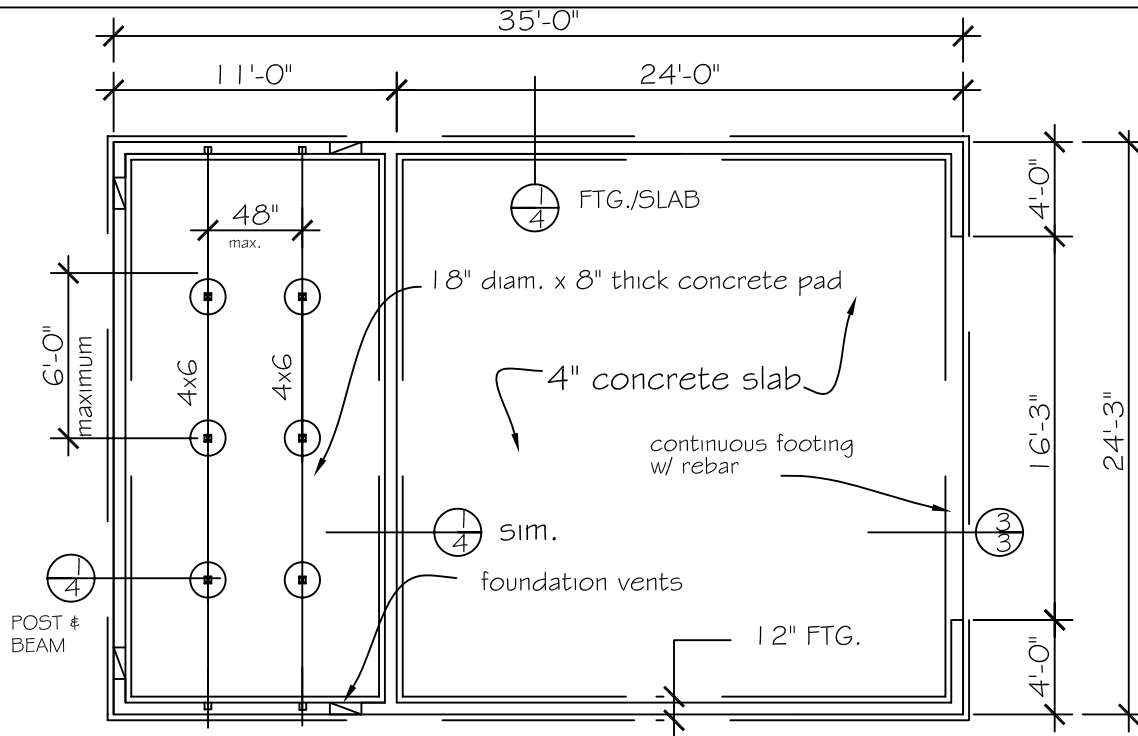

NOTE: If attaching addition to
to an existing residence, show
adjoining rooms of existing home

1 FOUNDATION/FLOOR FRAMING PLAN

scale- 1/4" = 1'-0" (REDUCED SCALE EXAMPLE) 35'-0"

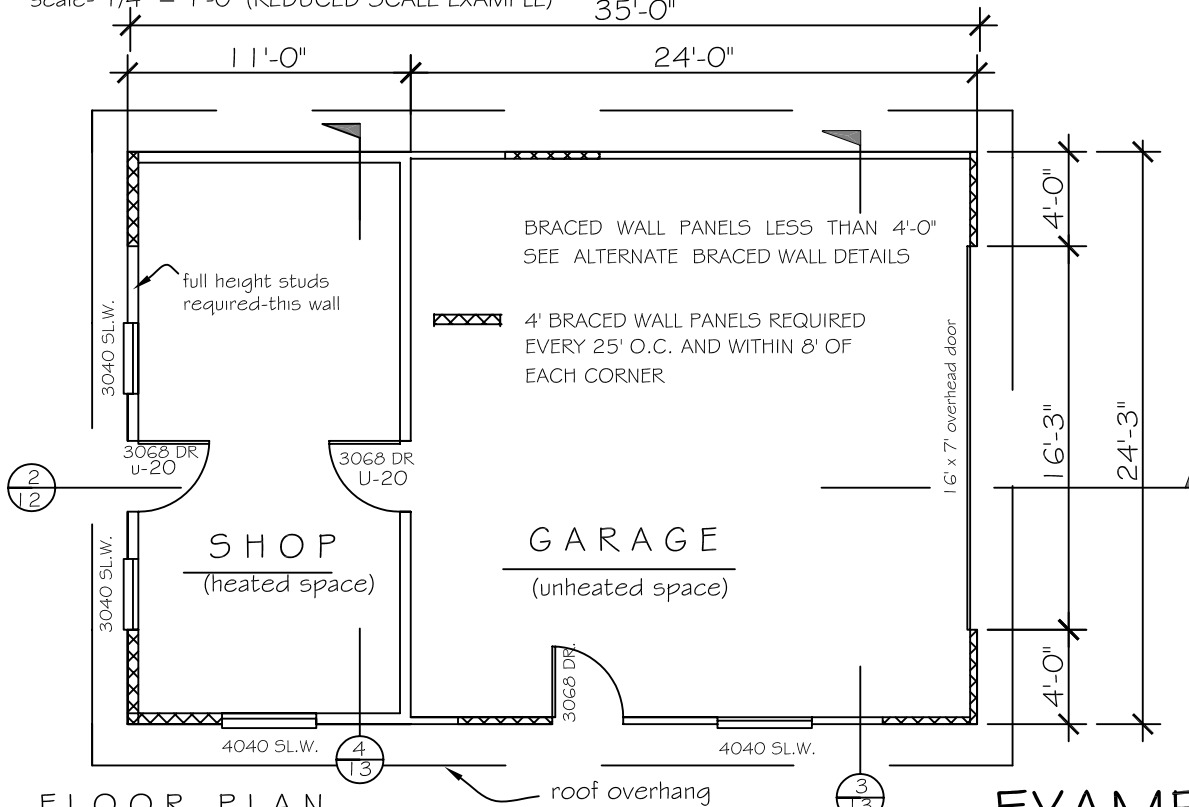

2 FLOOR PLAN

scale- 1/4" = 1'-0" (REDUCED EXAMPLE)

EXAMPLE